



FRAGMENTI
COTTO

FRAGMENTI

^{IT}/Narrare lo stretto rapporto tra materia e forma contraddistingue la ricerca di Fragmenti, un nuovo progetto di superfici decorative contemporanee.

Il progetto nasce dalla passione e la follia di un gruppo di giovani ragazzi italiani.

La PASSIONE per il design e per la progettazione d'interni.

La FOLLIA di guardare oltre il materiale e la sua tradizionale interpretazione progettuale.

A volte basta poco. Non serve urlare per farsi notare.

Different eyes. Wider views.

^{EN}/Narrating the close relationship between material and shape distinguishes Fragmenti's research, a new project of contemporary decorative surface.

The project born from the passion and the folly of some young Italian guys.

The PASSION about design and the interiors.

The FOLLY of seeing beyond the material and its traditional design interpretation.

Sometimes it doesn't take much. You don't need to scream to be noticed.

Different eyes. Wider views.

Contents

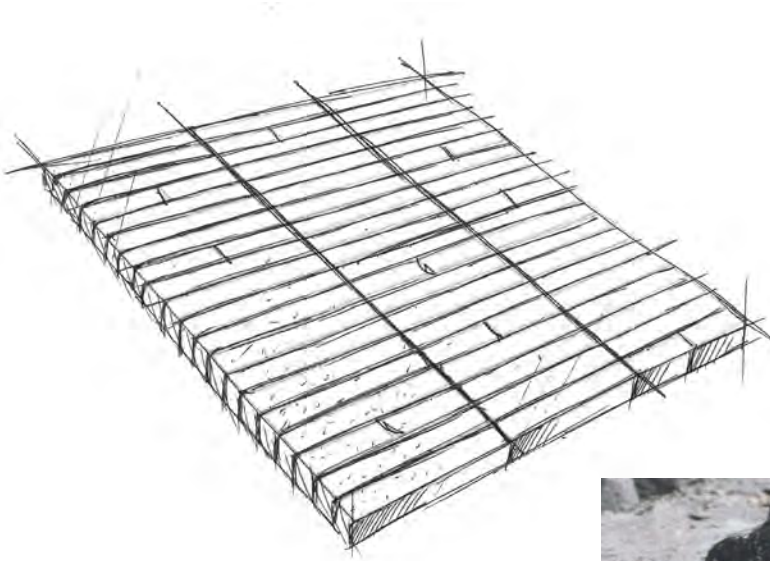

05



06

Intro Frammenti	p.01
Frammenti Cotto	p.04
Il Cotto di Impruneta	p.06
The Collection	p.12

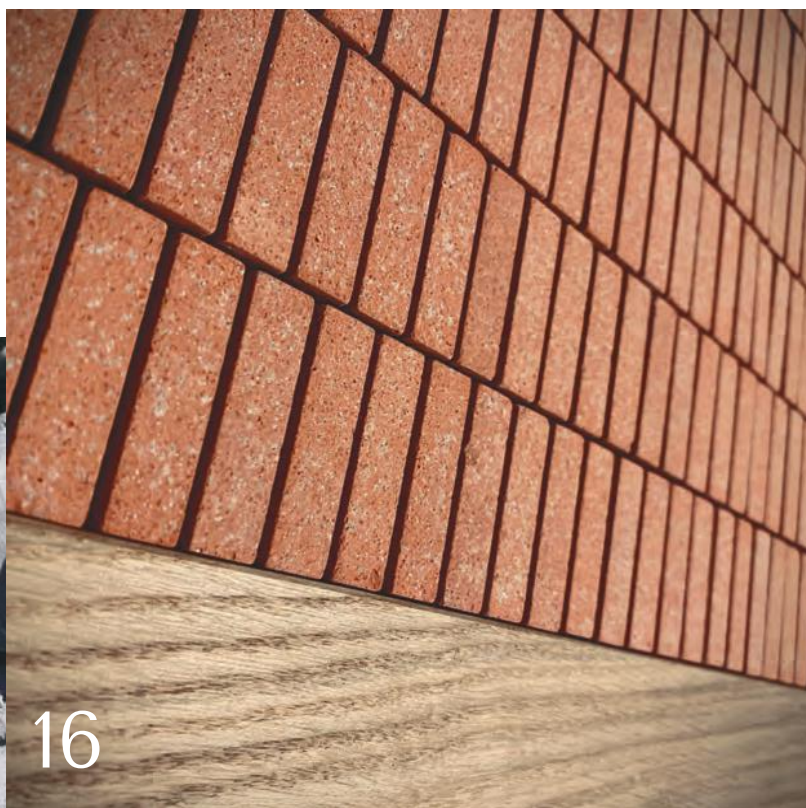

Layouts	p.62
Product Specifications	p.66
Technical features	p.68
Credits	p.70



FRAGMENTI
COTTO

Forme
contemporanee
abbracciano un
materiale dalle
radici storiche.

Contemporary lines
embrace a material
with historical roots.

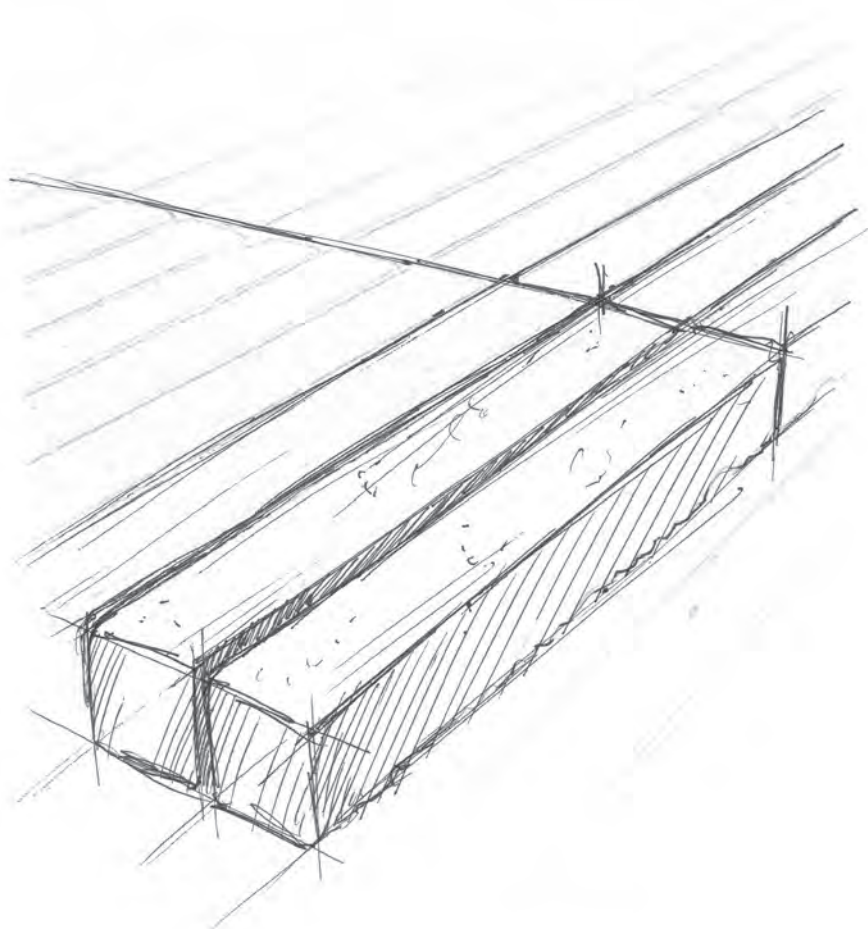

Fragmenti Cotto

IT/FRAGMENTI Cotto è una collezione di tessere di Mosaico in COTTO di IMPRUNETA dalla superficie "arrotata" ed angoli "burattati"

EN/FRAGMENTI Cotto is a program of COTTO di IMPRUNETA mosaic patterns with "arrotato" surface and "tumbled" edges.

IL COTTO DI IMPRUNETA

^{IT}/La collezione affonda le sue radici nel territorio di Impruneta vicino a Firenze, nelle valli dei fiumi Ema e Greve, ricco di un argilla unica nel suo genere chiamata Galestro. E' questa argilla che conferisce al Cotto di Impruneta una colorazione caratteristica e prestazioni tecniche superiori.

^{EN}The collection has its roots in the Impruneta area near Florence, in the valleys of the Ema and Greve rivers, rich in an unique clay called Galestro. It 's thanks to this particular clay that Cotto di Impruneta has its distinctive colour and superior technical performances.



galestro

FRAGMENTI
COTTO

clay



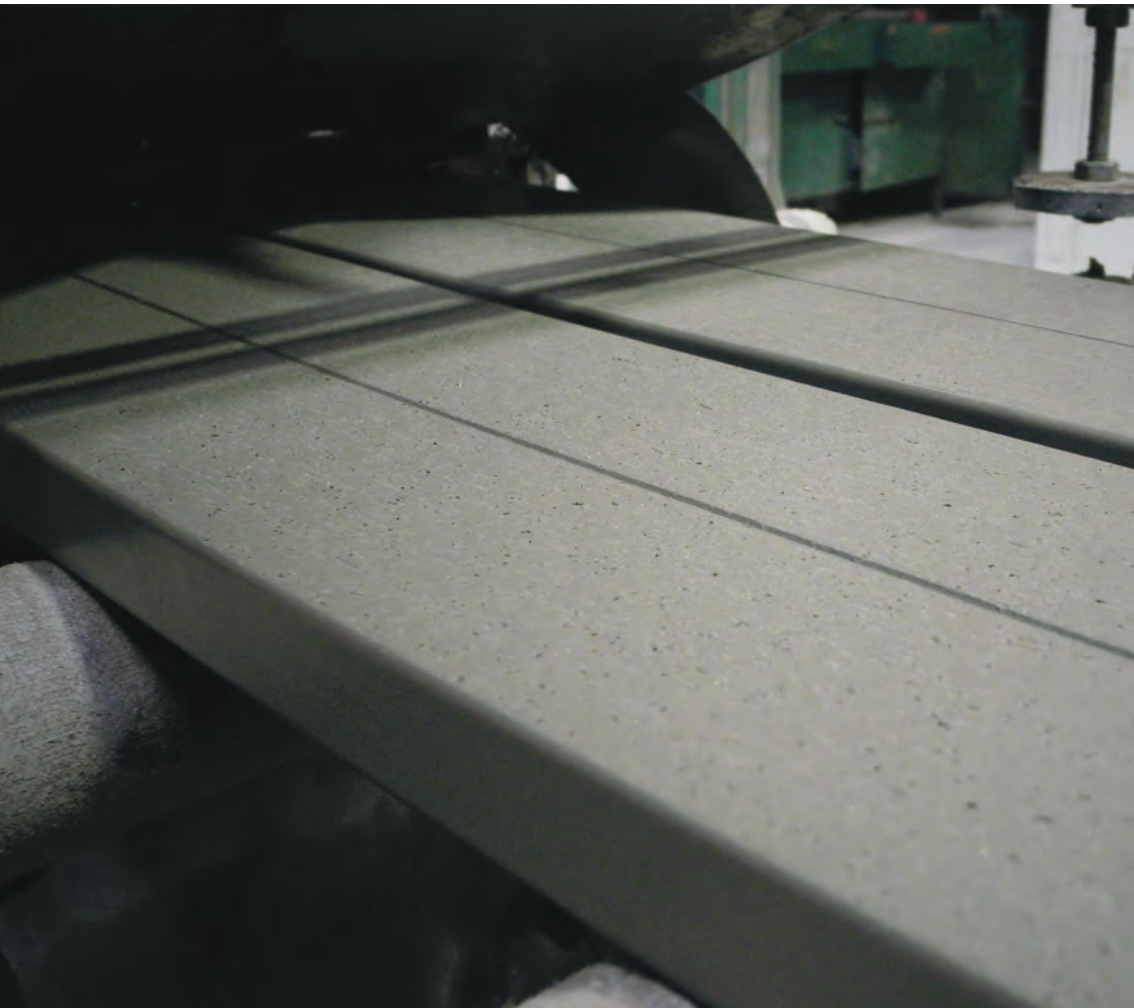

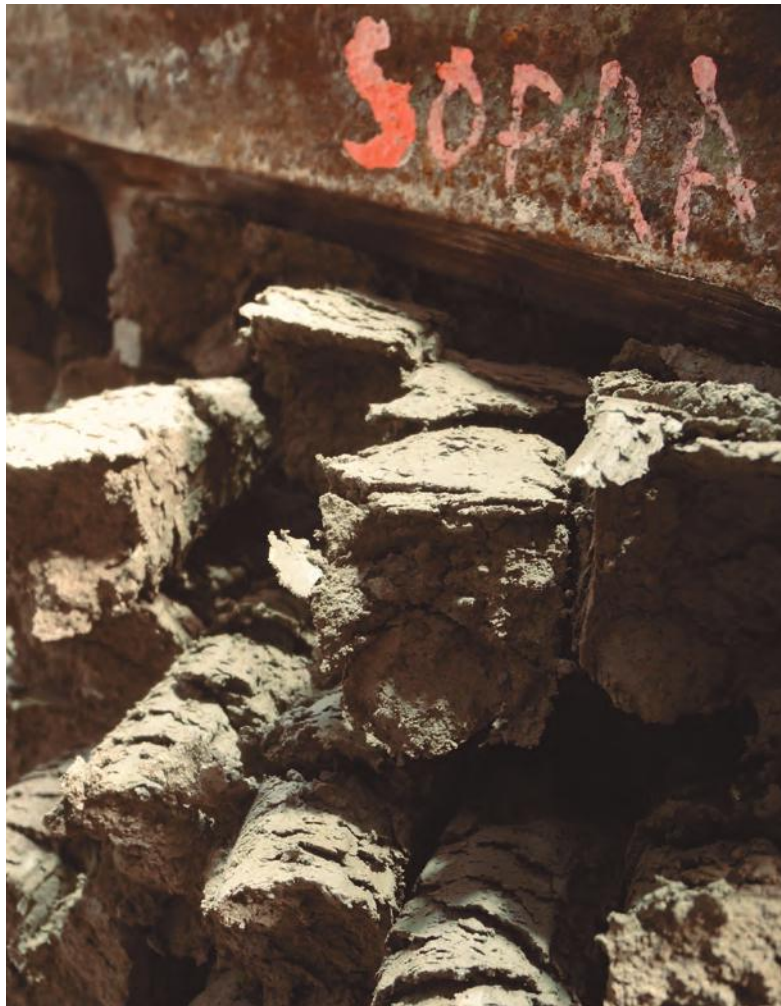

^{IT}/La lavorazione del materiale crudo con spazzole d'acciaio, detta ARROTATURA, "pulisce" il materiale dalle linee di estrusione conferendo al materiale la sua tipica superficie spazzolata.

^{EN}/The processing of the dried raw material with steel brushes, called "arrotatura", cleans the material from extrusion marks and gives it the typical cotto brushed surface.

arrotato

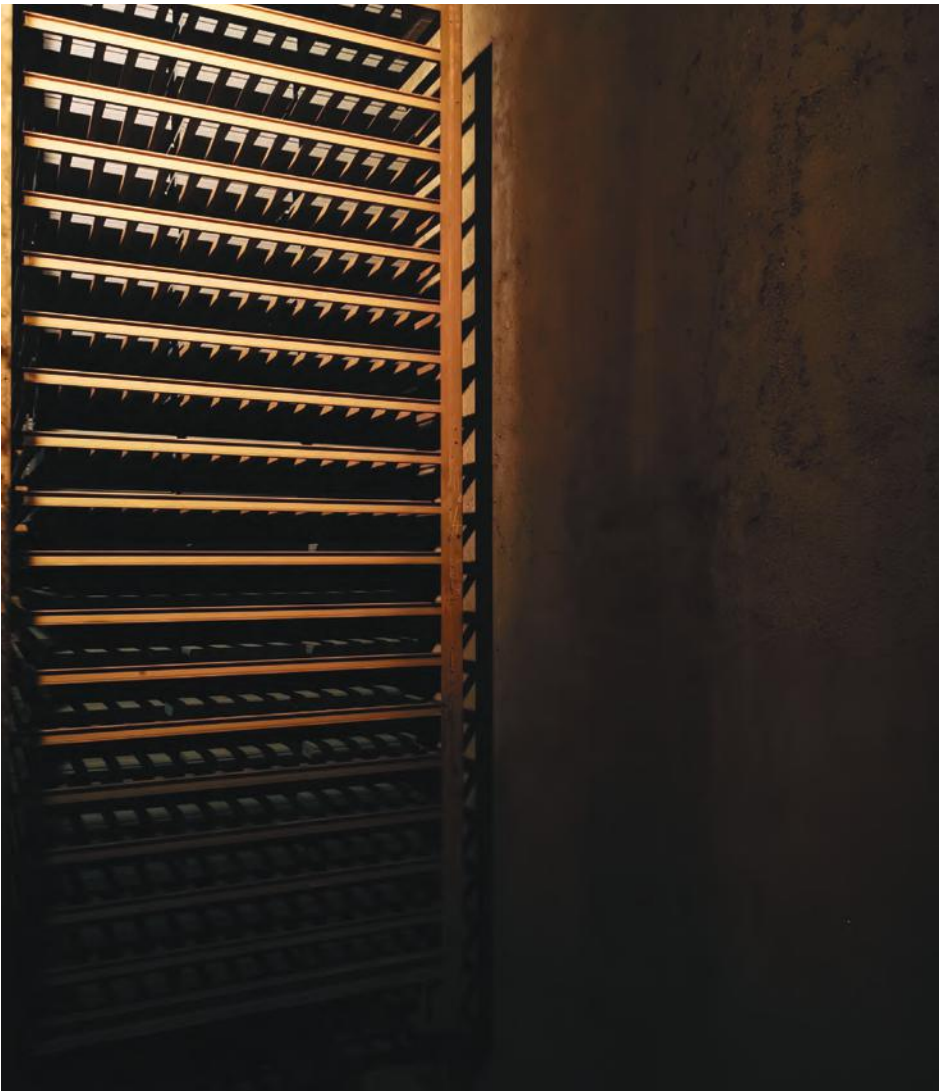
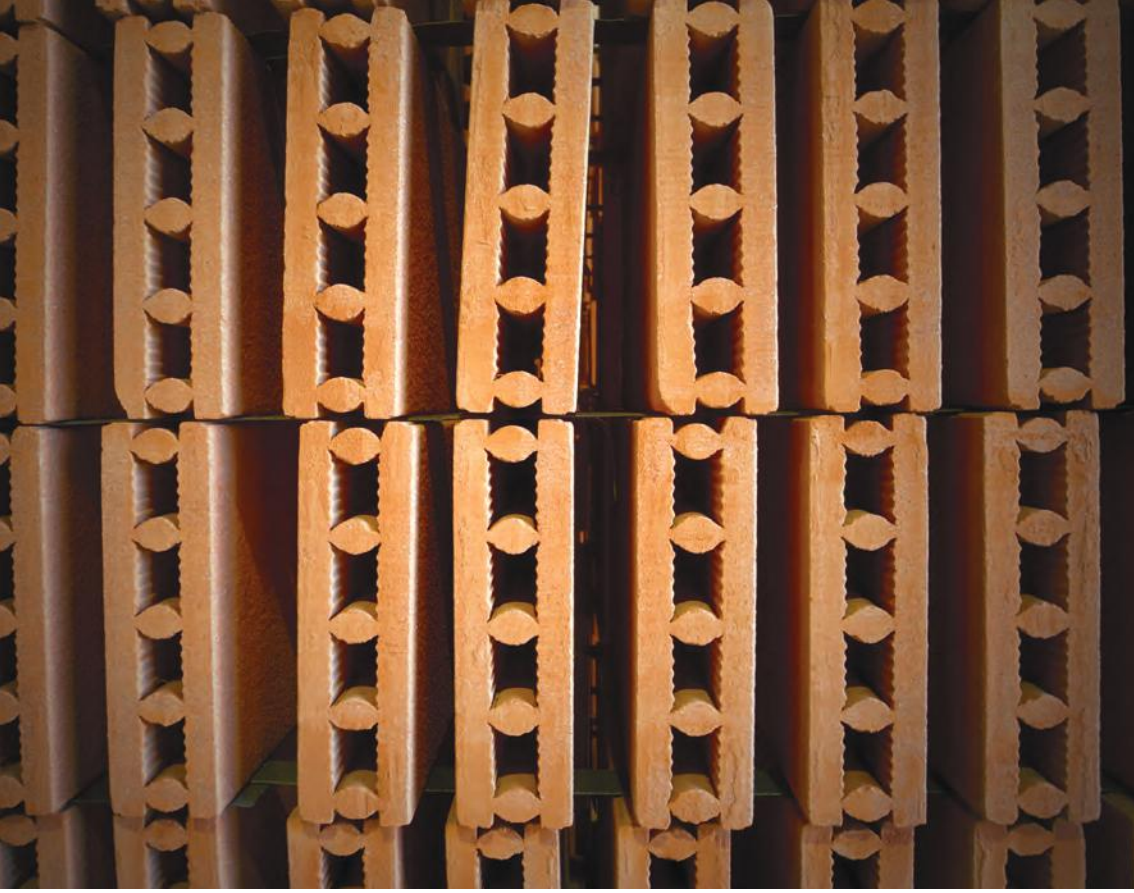

^{IT/}L'impasto di TERRA e ACQUA dopo essere stato degassato , trafilato e forgiato perde la sua naturale umidità mediante un processo di essiccazione ad ARIA forzata che dura fino a 42 ore.

Il FUOCO e le 72 ore di cottura a temperature prossime ai 1000 gradi forgianno la materia e gli conferiscono il carattere, la durezza e la resistenza che fanno del Cotto di Impruneta un'istituzione del made in Tuscany e del Made in Italy

^{EN/}The mixture of EARTH and WATER, after being degassed , extruded and shaped loses its natural moisture thanks to a long AIR drying process which takes up to 42 hours. The FIRE and the 72 hours of firing with temperatures close to 1000 degrees forge the material and give it the character and the strength which make Cotto di Impruneta a reference of the Made in Tuscany and Made in Italy.



THE COLLECTION



The essence
of simplicity



**Fragmenti Cotto
celebrates the
essential of the
material and the
purity of the
shapes**

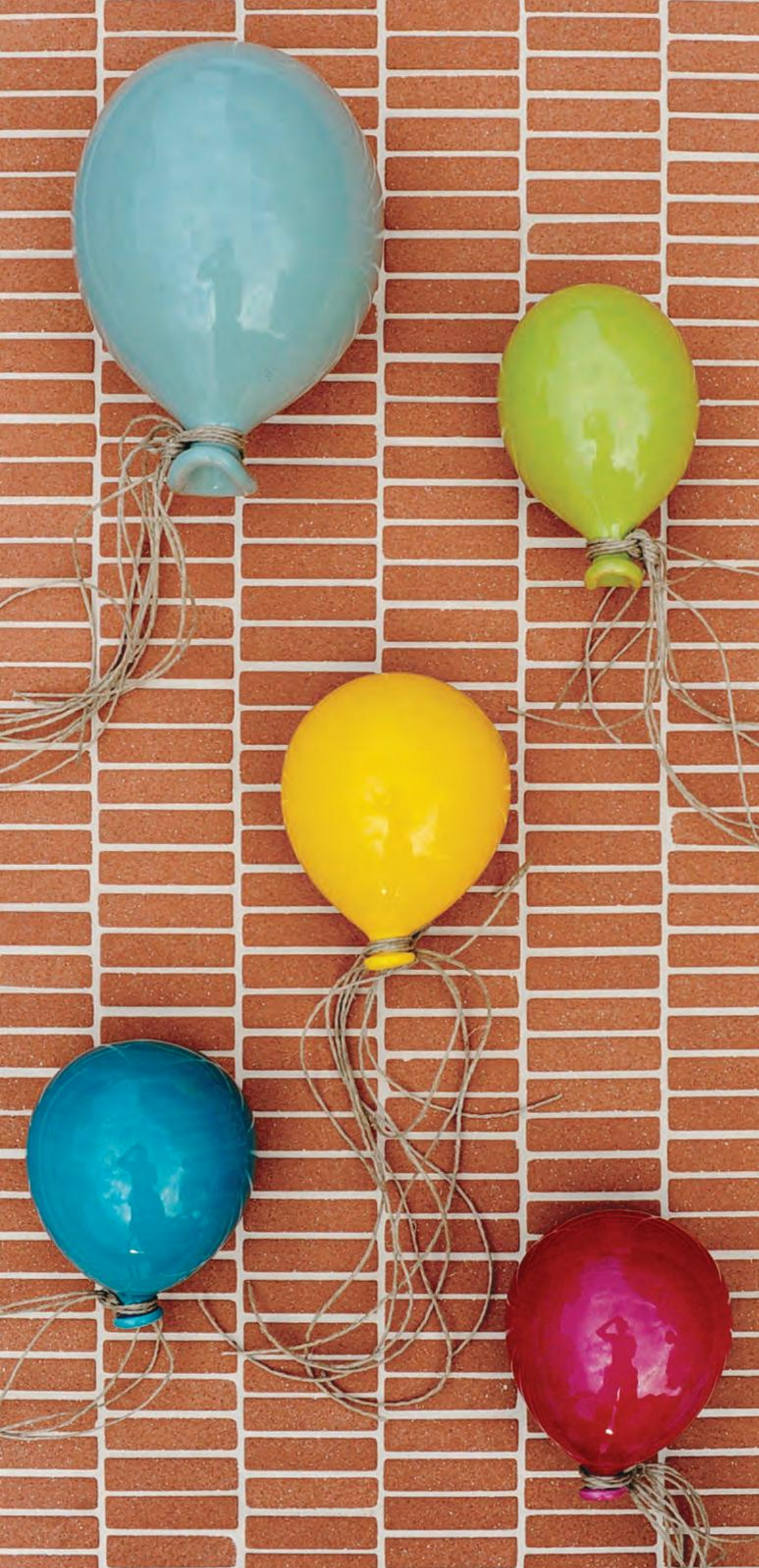





Material still matters



A close-up photograph of a textured, reddish-brown material, possibly a piece of wood or stone, with a rough, porous surface. The material is arranged in a series of parallel, slightly overlapping strips. The lighting is warm, highlighting the texture and color. In the bottom right corner, the words "Red Passion" are written in a white, serif font.

Red
Passion



Natural
elements.
Contemporary
vibes.





Bathroom

FRG013148000
Lungo_01





Bathroom | FRG13098000
Corto_02





Bathroom | FRG13098000
Corto_02





Public Space

FRG023148000
Lungo_02







Kitchen | FRG013048000
Corto_01



**When you grout it
in black, you never
come back.**









Outdoor

FRG023298000
Lungo_03



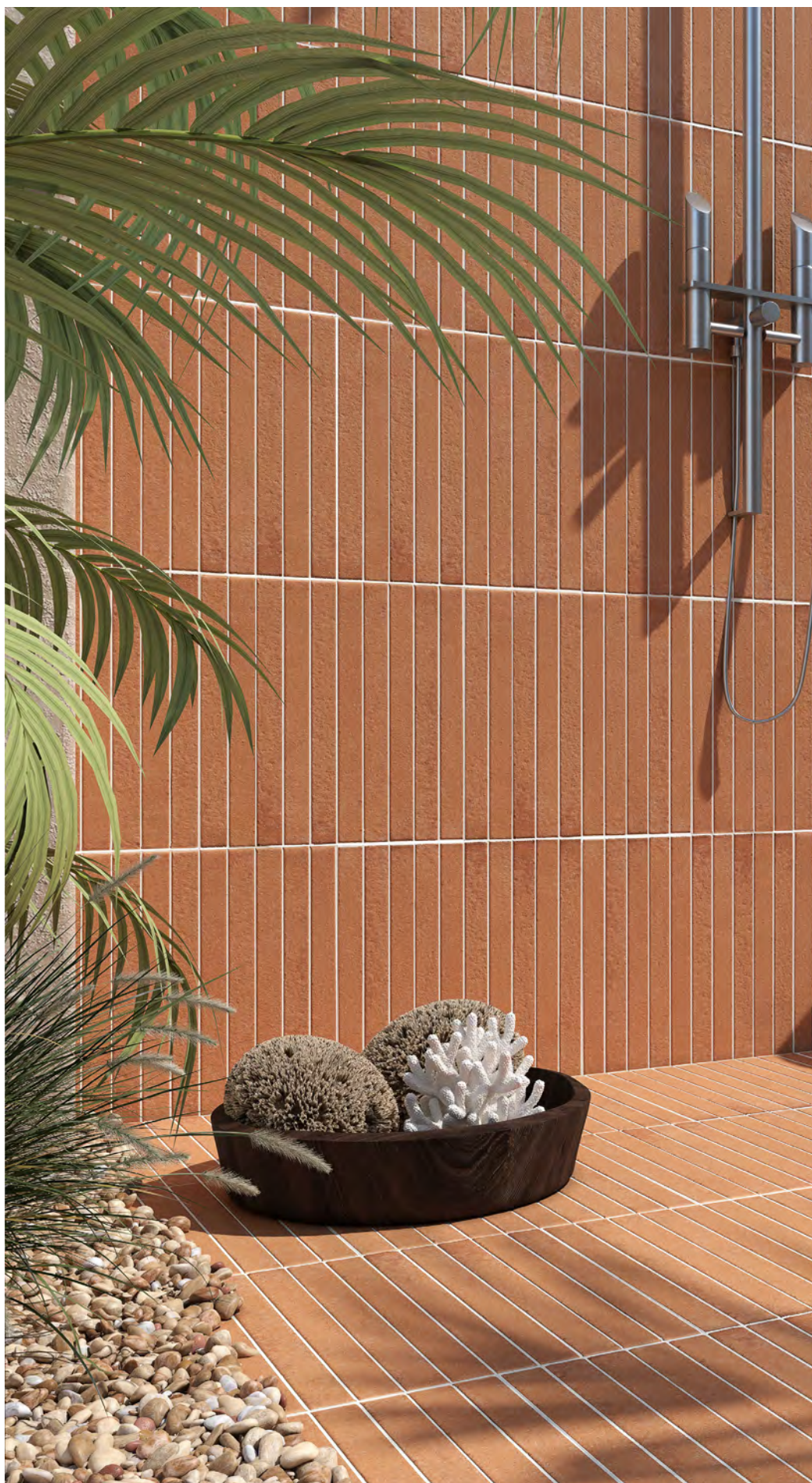

Outdoor

FRG023298000
Lungo_03





Living

FRG013148000
Lungo_01



#befrag



Kitchen | FRG013098000
Corto_02





Don't be
shy. It
loves colours.





Bathroom | FRG023148000
Lungo_02



Bathroom | FRG023148000
Lungo_02



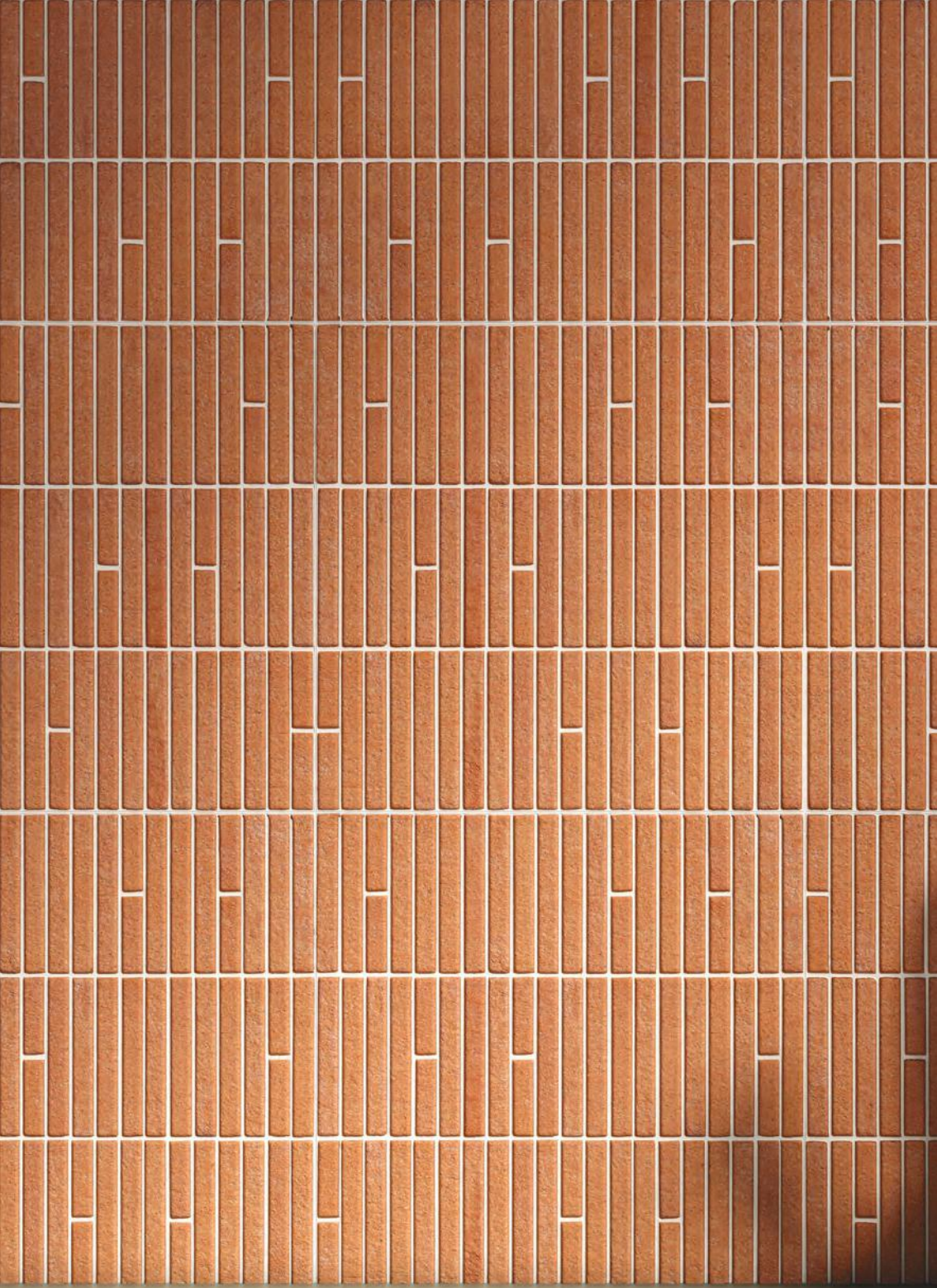

Kitchen

FRG013048098
Corto_03





Kitchen

FRG013048098
Corto_03







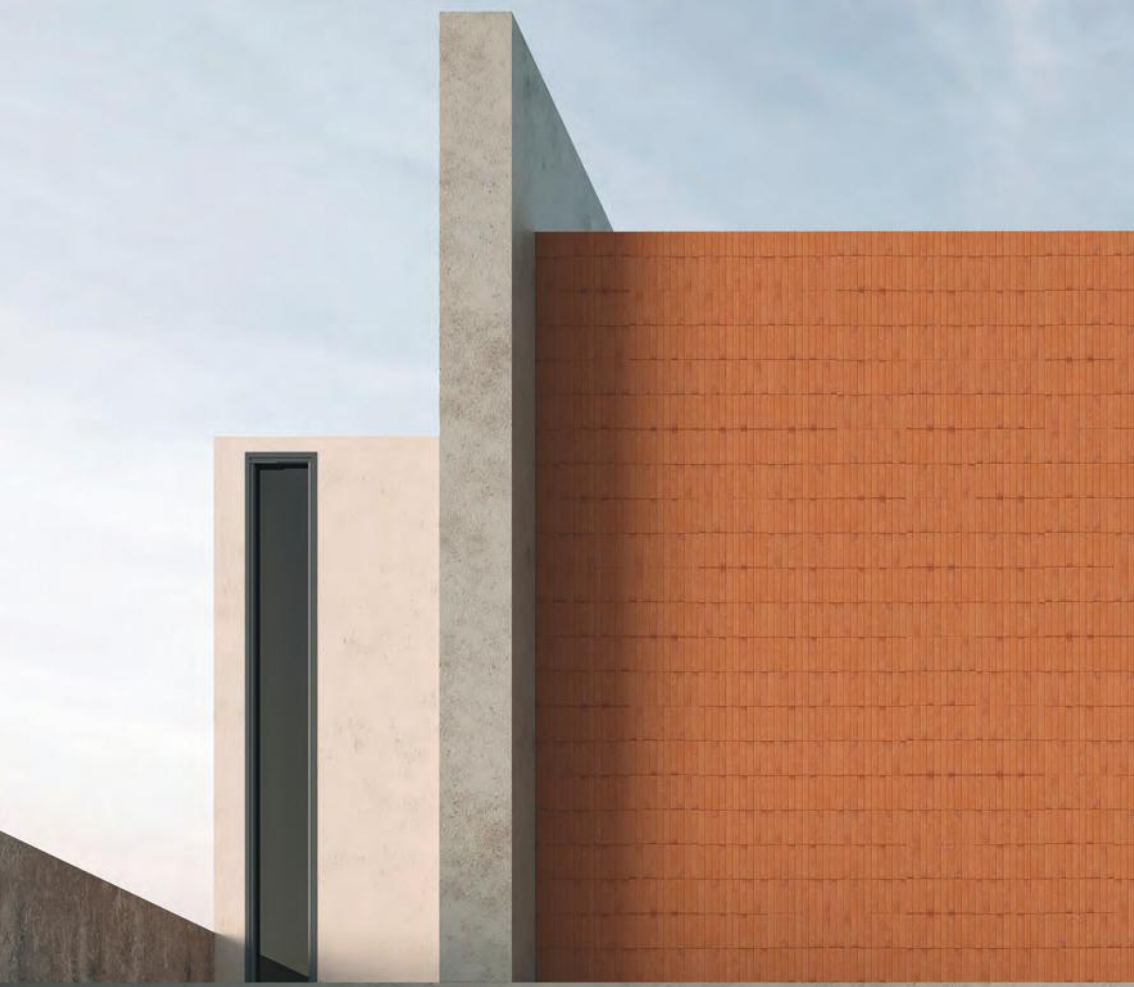

LevelUp



Outdoor

FRG023148000
Lungo_02

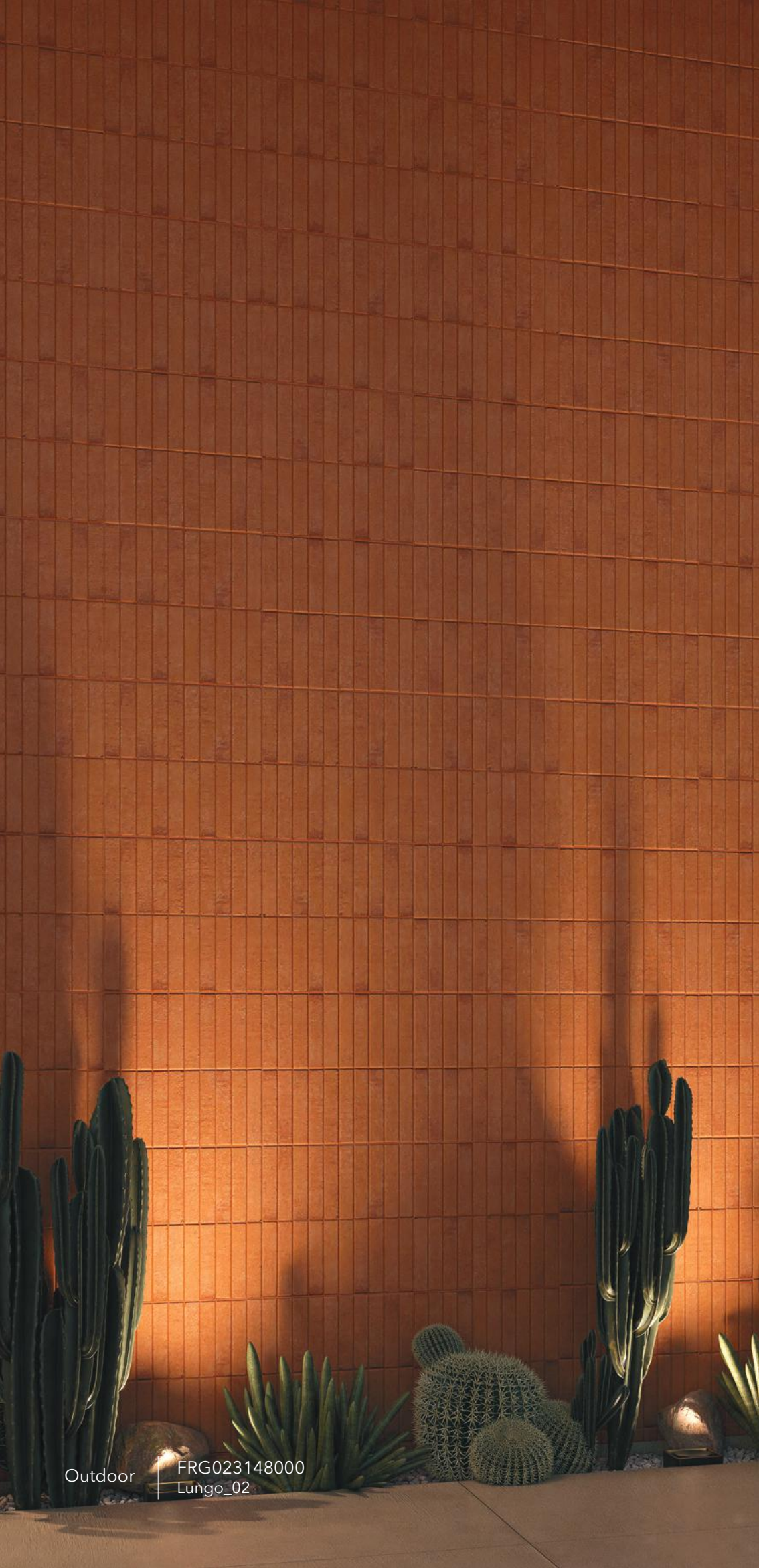

Outdoor | FRG023148000
Lungo_02







Bathroom

FRG013148000
Lungo_01



Bathroom | FRG013148000
Lungo_01





Bedroom

FRG023298000
Lungo_03



**Skinny
shapes.
Classic
dreams.**

LAYOUTS

FRG013048000
Corto_01

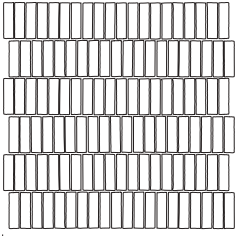

298x298 mm
12"x12"
module
13x48 mm
0¹/₂"x1⁷/₈"

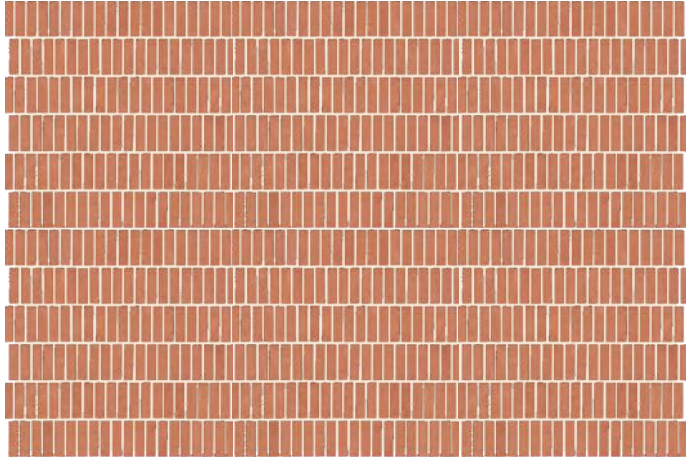

ULTRACOLOR PLUS
130 Jasmine

FRG013098000
Corto_02

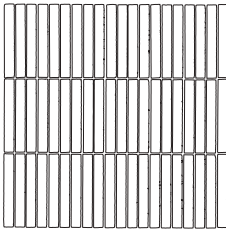

298x298 mm
12"x12"
module
13x98 mm
0¹/₂"x3⁷/₈"

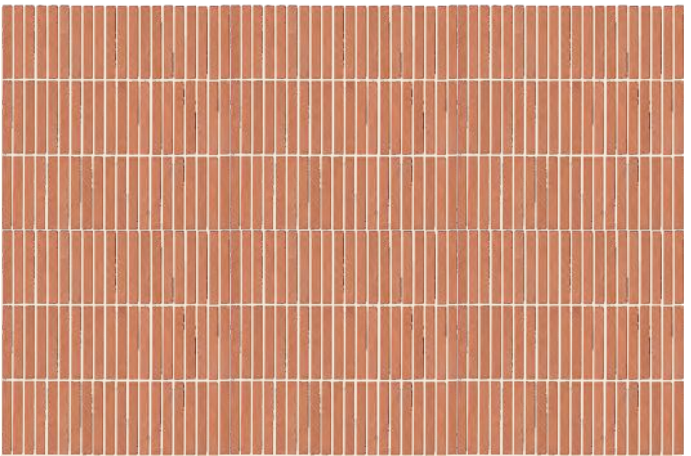

ULTRACOLOR PLUS
130 Jasmine

FRG013048098
Corto_03

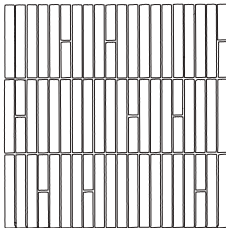

298x298 mm
12"x12"
module 13x48 mm 0¹/₂"x1⁷/₈" | module 13x98 mm 0¹/₂"x3⁷/₈"

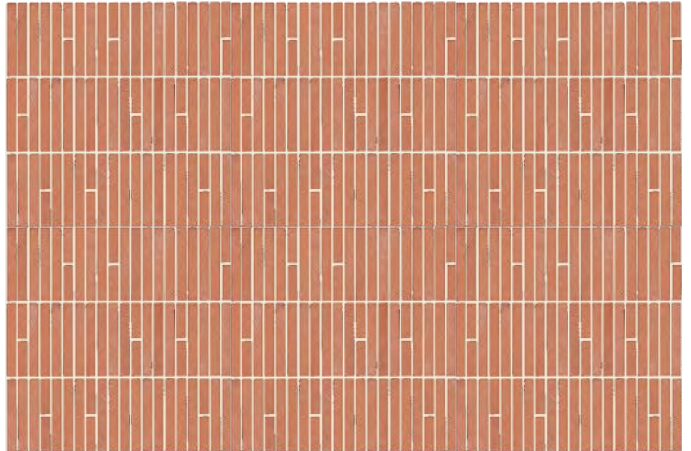

ULTRACOLOR PLUS
130 Jasmine

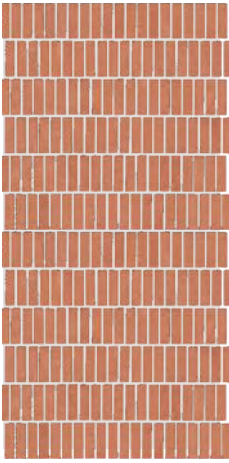

ULTRACOLOR PLUS
111 Grigio Argento

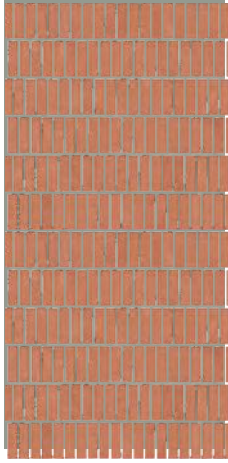
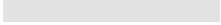

ULTRACOLOR PLUS
115 Grigio Fumè

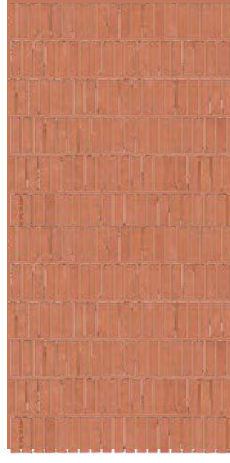

ULTRACOLOR PLUS
145 Terra di Siena

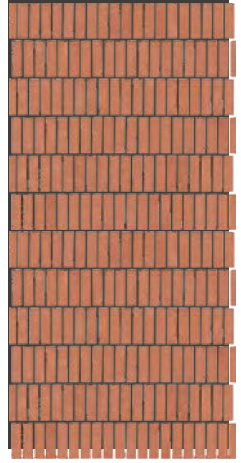

ULTRACOLOR PLUS
120 Black



ULTRACOLOR PLUS
111 Grigio Argento

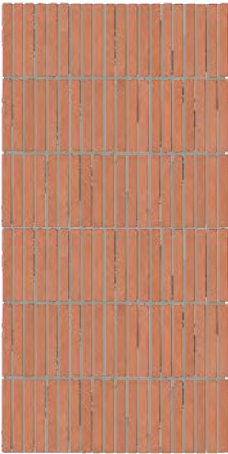
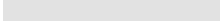

ULTRACOLOR PLUS
115 Grigio Fumè

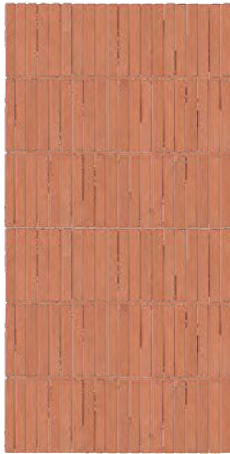

ULTRACOLOR PLUS
145 Terra di Siena

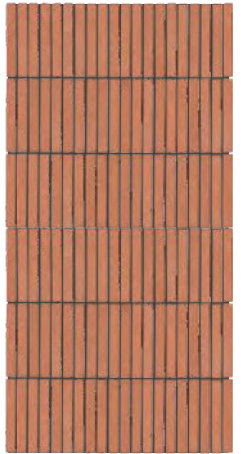

ULTRACOLOR PLUS
120 Black

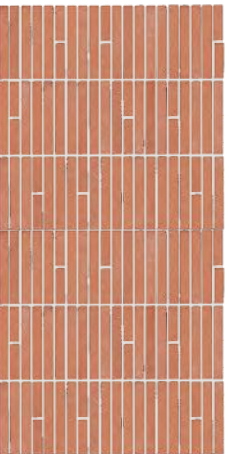

ULTRACOLOR PLUS
111 Grigio Argento

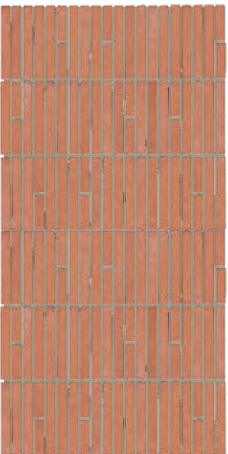

ULTRACOLOR PLUS
115 Grigio Fumè

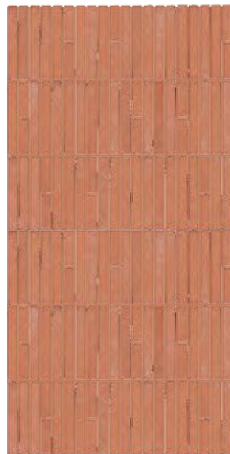

ULTRACOLOR PLUS
145 Terra di Siena

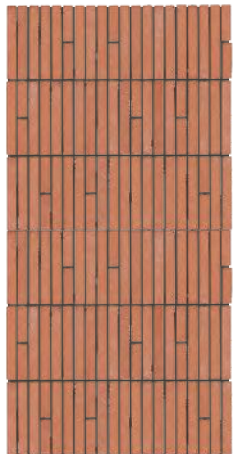

ULTRACOLOR PLUS
120 Black



LAYOUTS

FRG013148000
Lungo_01

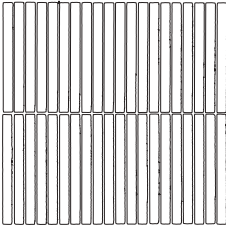

298x298 mm
12"x12"

module
13x148 mm
0¹/₂"x5¹³/₁₆"

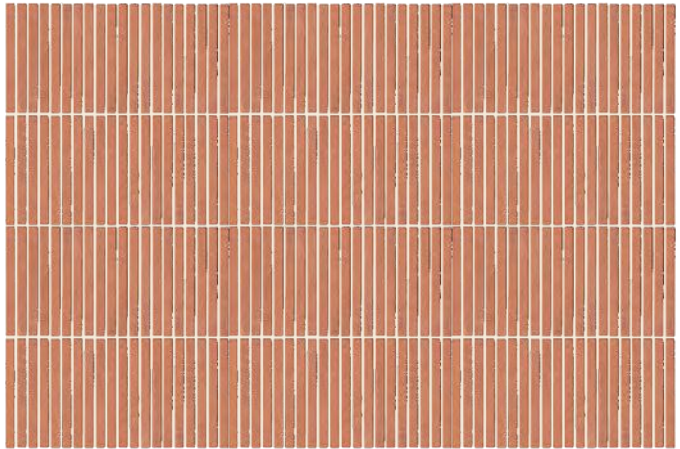

ULTRACOLOR PLUS
130 Jasmine

FRG023148000
Lungo_02

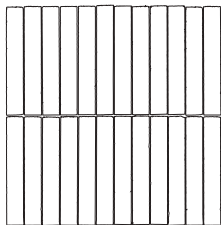

298x298 mm
12"x12"

module
28x148 mm
1³/₃₂"x5¹³/₁₆"

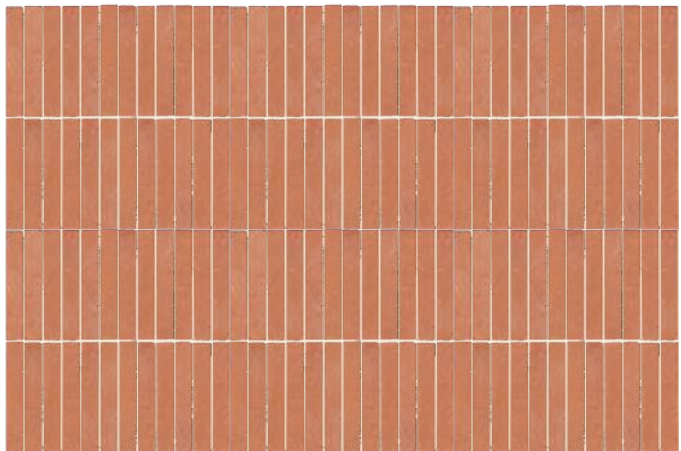

ULTRACOLOR PLUS
130 Jasmine

FRG023298000
Lungo_03

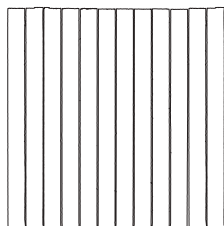

298x298 mm
12"x12"

module
28x298 mm
1³/₃₂"x12"

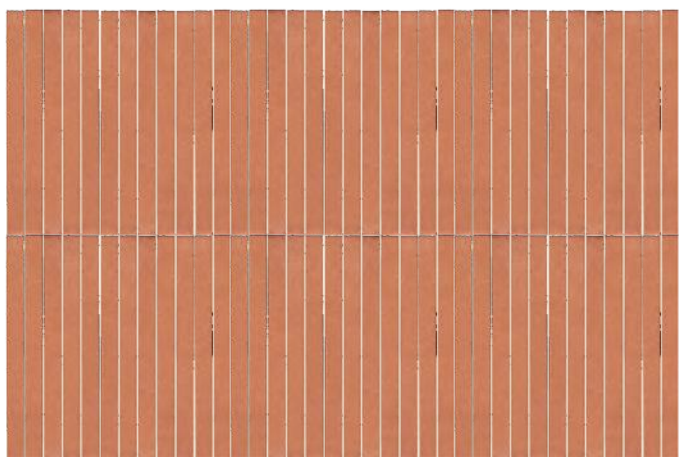

ULTRACOLOR PLUS
130 Jasmine



ULTRACOLOR PLUS
111 Grigio Argento

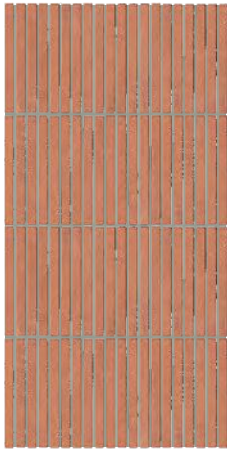

ULTRACOLOR PLUS
115 Grigio Fumè

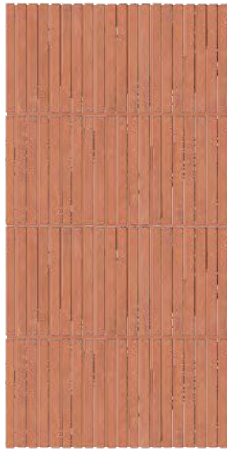

ULTRACOLOR PLUS
145 Terra di Siena



ULTRACOLOR PLUS
120 Black



ULTRACOLOR PLUS
111 Grigio Argento



ULTRACOLOR PLUS
115 Grigio Fumè

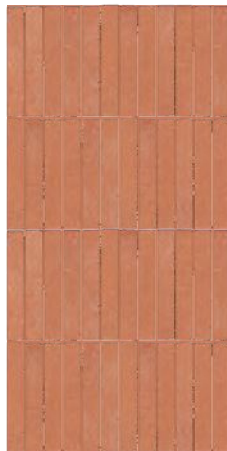

ULTRACOLOR PLUS
145 Terra di Siena



ULTRACOLOR PLUS
120 Black

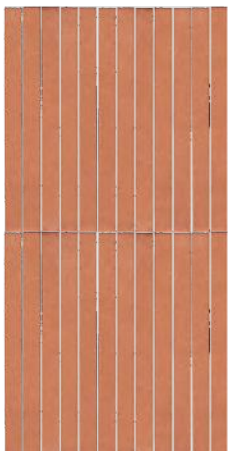

ULTRACOLOR PLUS
111 Grigio Argento



ULTRACOLOR PLUS
115 Grigio Fumè



ULTRACOLOR PLUS
145 Terra di Siena

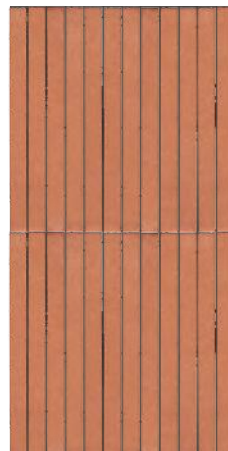

ULTRACOLOR PLUS
120 Black



PRODUCT SPECIFICATION

Corto

Moduli | Module

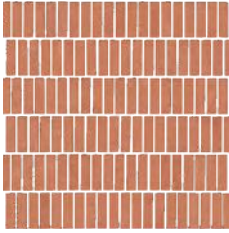

FRG013048000
Corto_01

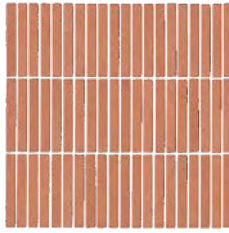

FRG013098000
Corto_02

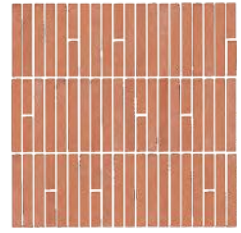

FRG013048098
Corto_03

Dimensioni | Size

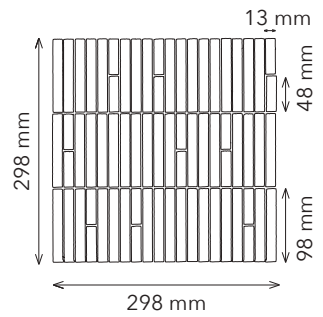
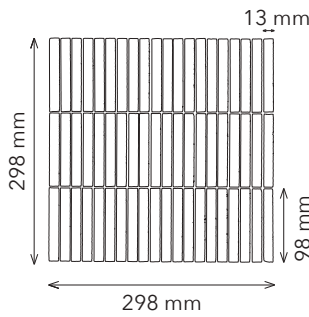
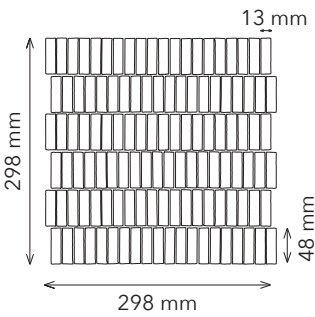

Spessore | Thickness

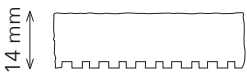

Prodotto artigianale. Foto e dettagli tecnici non definiscono i dettagli precisi ed esatti del prodotto. Le misure riportate nel catalogo sono puramente a scopo indicativo.

Materiale | Material

Cotto | Terracotta



Wall



Floor

Colore | Colour



ROSSO
IMPRUNETA

Le colorazioni dei prodotti riportati sul catalogo sono da ritenersi puramente indicative e non hanno valore di prova colore.
The colours printed in this catalogue have to be considered merely indicative and have no colour proof value.

Lungo

Moduli | *Module*

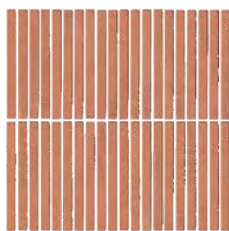

FRG013148000
Lungo_01



FRG023148000
Lungo_02



FRG023298000
Lungo_03

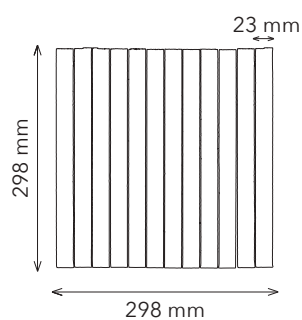
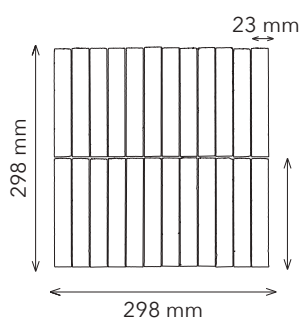
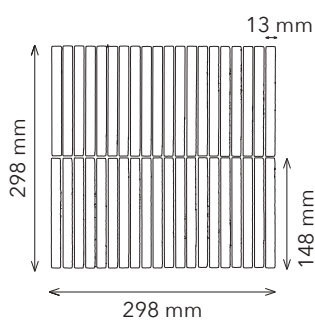

Artisan products. Pictures and technical drawings do not define the details of the product. The measurements shown are indicative only.

Fuga | *Joint*

2mm

Fugante Cementizio | *Cementitious grout*

Finitura | *Finishing*

Naturale | *Natural*

Superficie | *Surface*

Arrotata | *Brushed*

Angoli | *Edges*











Burattati | *Tumbled*



TECHNICAL FEATURES

DIMENSIONAL PROPERTIES Norm UNI EN ISO 10545-2	Lenght (mm)	Width (mm)	Thickness (mm)	Straightness of the edges	Ortogonalità	Flatness
	± 1,5%	± 1,5%	± 10%	± 1,0%	± 1,0%	± 1,5%

(1) Dimensional tolerances have to be intended for the same lot of production
The section of the file does not allow the execution of the test. Typical value of the material 20 N / mm²

COMMON FEATURES	NORM	OUTCOME
 Water absorption	UNI EN ISO 10545-3	7%
 Deep abrasion resistance	UNI EN ISO 10545-6	544 mm ³
 Thermal linear expansion	UNI EN ISO 10545-8	5,8 (10 ⁻⁶ /°C)
 Thermal shock resistance	UNI EN ISO 10545-9	Resistent
 Expansion to humidity in boiling water	UNI EN ISO 10545-10	0,01 mm/m
 Frost resistance	UNI EN ISO 10545-12	Resistent
 Chemical resistance	UNI EN ISO 10545-13	Resistent
 Stain resistance	UNI EN ISO 10545-14	Removable stains
 Slip resistance	DIN 51097	> 35°
 Anti Slip properties	DIN 51130	> 35° - R13
 Mohs' hardness	UNI EN 101	6

PACKAGING

CODE	NAME	PC/BOX	SQM/BOX	Kg/BOX	BOX/plt	SQM/plt	Kg/plt
FRG013048000	Corto_01	6	0,53	16	42	22,26	697
FRG013098000	Corto_02	6	0,53	16	42	22,26	697
FRG013048098	Corto_03	6	0,53	16	42	22,26	697
FRG013148000	Lungo_01	6	0,53	16	42	22,26	697
FRG023148000	Lungo_02	6	0,53	16	42	22,26	697
FRG023298000	Lungo_03	6	0,53	16	42	22,26	697
CODE	NAME	PC/BOX	IM/BOX	Kg/BOX			
FRG014020500	Profilo_01	8	4	1,5			
FRG025020500	Profilo_02	8	4	2			
FRG014050500	Profilo_03	6	3	3			

Profili

Moduli | *Module*



FRG014020500
Profilo_01



FRG025020500
Profilo_02



FRG014050500
Profilo_03

Dimensioni | *Size*

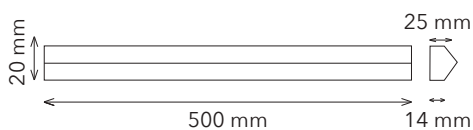

Materiale | *Material*

Legno massello | *Solid wood*

Colore | *Color*

Rovere | *Oak*

Finitura | *Finishing*

Oliato Naturale | *Natural oiled*

Superficie | *Surfaces*

Spazzolata | *Brushed*

Angoli | *Edges*

Bisellati | *Microbevelled*



Credits



GIACOBAZZI



NIC

AN·TRAX IT



Colophon

Art Direction: D-Segno Studio
Graphic Design: D-Segno Studio

Via Caula, 18/A
41049 Sassuolo(MO) - Italy T.
+39 348.8744890
P.iva 02651960359
info@d-segno.com
d-segno.com

Frammenti e' un marchio di DPLUS39 srl.
All right reserved 2021



DPLUS39 s.r.l.
Via Giardini 464/N
41124 Modena, ITALY
info@fragmenti.it

All rights reserved. Not any part
of this work can be reproduced
in any way without the written
authorizathion by DPLUS39.

www.fragmenti.it

